

## CARATTERISTICHE

- Costruiti interamente in plastica, polipropilene o PVDF
- Realizzati in un unico pezzo
- Nessuna giuntura o saldatura
- Rinforzato con fibra di vetro
- Resistente ad alte pressioni e temperature
- Connessioni: Filettato (B) o Flangiato (D)



Filettato BSP

Flangiato

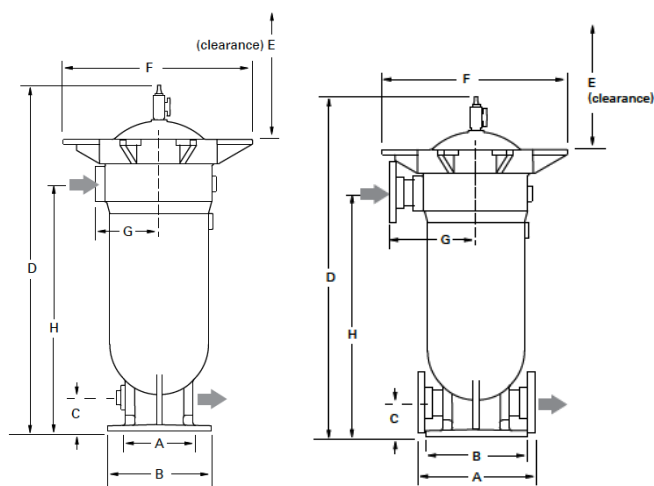

Pressione di esercizio ammissibile a temperatura

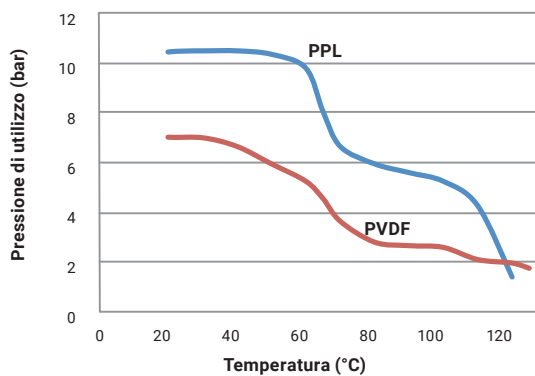

| POL - S             |   | 0101-PO10-050B | 0102-PO10-050B | 0101-PO10-050D | 0102-PO10-050D | 0102-PF06-050D |
|---------------------|---|----------------|----------------|----------------|----------------|----------------|
| Pressione max (bar) |   | 10             | 10             | 10             | 10             | 7              |
| Temp max (°C)       |   | 20             | 20             | 20             | 20             | 20             |
| Materiale           |   | PPL            | PPL            | PPL            | PPL            | PVDF           |
| Dimensioni (mm)     | A | 165            | 165            | 145            | 145            | 145            |
|                     | B | 254            | 254            | 254            | 254            | 254            |
|                     | C | 83             | 83             | 83             | 83             | 83             |
|                     | D | 867            | 1273           | 867            | 1273           | 1273           |
|                     | E | 508            | 914            | 508            | 914            | 914            |
|                     | F | 467            | 467            | 467            | 467            | 467            |
|                     | G | 156            | 156            | 219            | 219            | 219            |
|                     | H | 607            | 1013           | 607            | 1013           | 1013           |
| Volume (l)          |   | 25             | 36             | 25             | 36             | 36             |
| N° di sacchi        |   | 1              | 1              | 1              | 1              | 1              |
| Mis. sacchi         |   | 01             | 02             | 01             | 02             | 02             |
| Portata max (m³/h)  |   | 12             | 24             | 12             | 24             | 24             |
| Sfiato              |   | 1/4" BSP       | 1/4" BSP       | 1/4" BSP       | 1/4" BSP       | 1/4" BSP       |
| Peso (kg)           |   | 23             | 29             | 25             | 31             | 46             |
| Conn. IN e OUT      |   | 2" BSP F       | 2" BSP F       | DN 50          | DN 50          | DN 50          |