

## SPECIFICATIONS

- Quick strainer opening and extraction
- Strainers from 38 to 1000 microns
- Threaded (3/8" - 3") and flanged (1" - 8") connections
- Standard stainless steel filter strainers
- Differential pressure switches
- Magnetic insert
- Available in Cast Iron, Carbon Steel, Stainless Steel and Bronze
- Operating pressure: 13.8 bar at 40°C

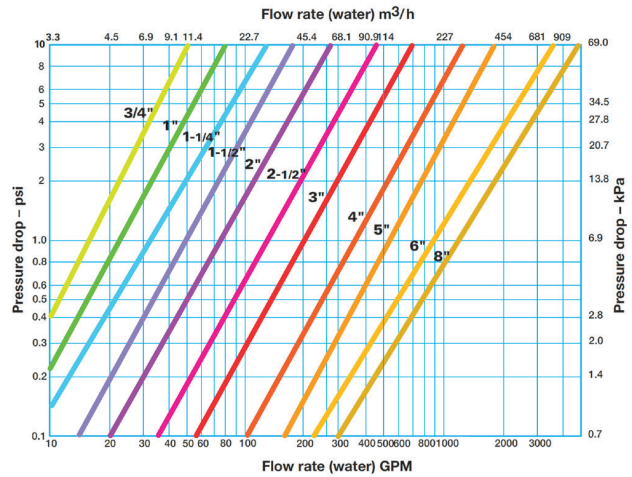
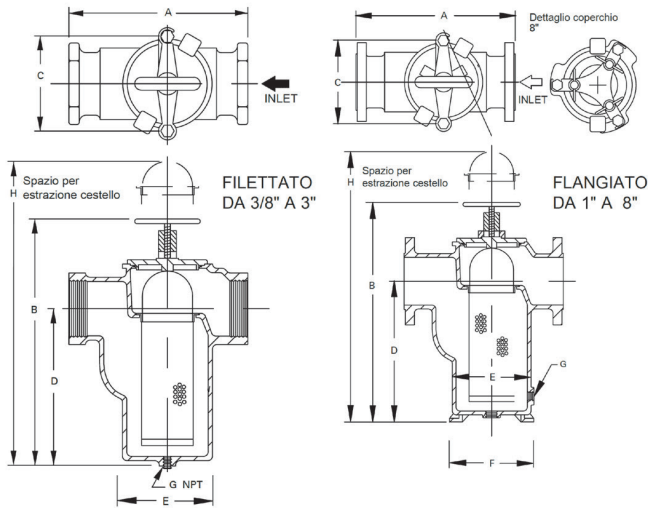

### Sizes in mm - Threaded

Size	A	B	C	D	E	F	G	H	Dry weight per material - kg			
									BR	AC	CI	X
3/8"	102	168	73	102	60	-	3/8"	279	1.8	-	1.8	-
1/2"	102	168	73	102	60	-	3/8"	279	1.8	-	1.8	-
3/4"	137	213	102	127	78	-	1/2"	330	3.6	-	3.2	-
1"	137	213	102	127	78	-	1/2"	330	3.6	3.2	3.2	3.2
1" 1/4	172	251	124	149	99	-	1/2"	356	6	-	6	-
1" 1/2	184	279	124	178	102	-	3/4"	406	7	7	7	7.3
2"	222	340	172	194	130	-	1" 1/4	533	15	16	14	14
2" 1/2	264	378	203	219	162	-	1" 1/2	660	22	24	23	23
3"	292	468	203	298	168	-	1" 1/2	711	27	27	23	27

### Sizes in mm - Flanged

Size	A	B	C	D	E	F	G	H	Dry weight per material - kg			
									BR	AC	CI	X
1"	194	213	102	127	-	-	1/2"	330	7	4	4	4
1" 1/2	260	279	124	178	-	-	3/4"	406	14	7.7	7.7	7.7
2"	268	349	172	194	130	159	3/8"	508	22.3	16	17	16
2" 1/2	295	397	203	226	162	194	3/8"	584	29.1	27	25	29
3"	334	457	203	270	165	203	3/8"	686	38.6	-	35	-
3"	334	476	202	305	165	203	1/2"	686	-	39	-	39
4"	425	505	273	273	245	289	1/2"	762	63.6	-	55	-
4"	438	505	272	272	235	289	1/2"	762	-	59	-	59
5"	461	638	273	387	254	289	1/2"	1041	82.7	-	77.5	-
6"	499	724	272	467	254	289	1/2"	1168	122.7	107	91	107
8"	686	1029	-	686	349	445	1/2"	1524	272.7	250	227	250

### Filter composition code

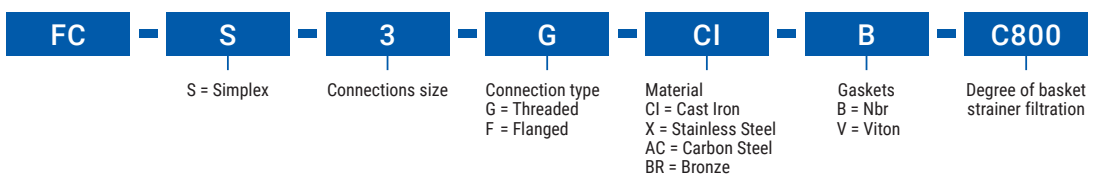

### Strainer composition code

